

# NEC

# Electra **Elite**<sup>®</sup> IPK

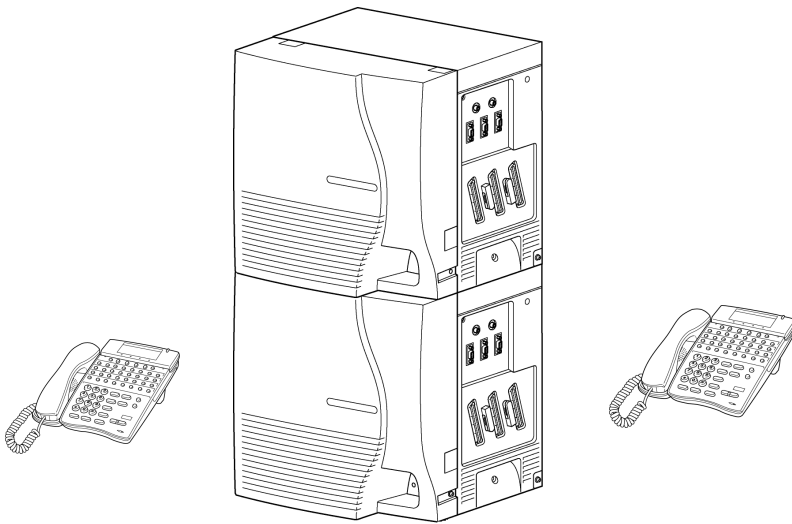

## Multiline Telephone User Guide

# ELITE IPK TELEPHONES

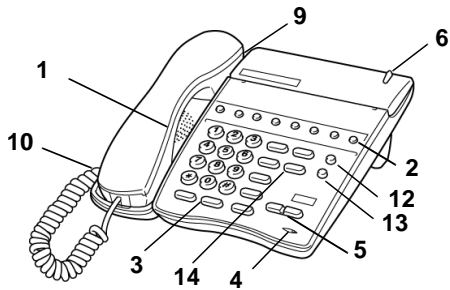

8-Button Non Display

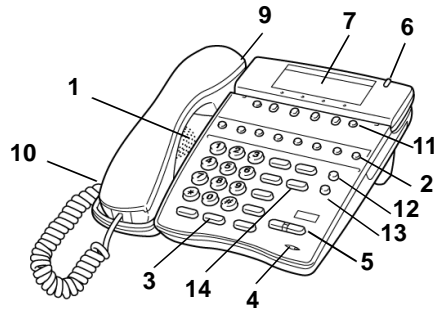

8-Button Display

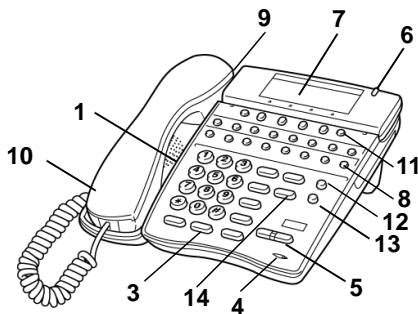

16-Button Display

1 Speaker	6 Large LED	11 Softkeys
2 Line Keys/Feature Access Keys	7 Alphanumeric Display	12 Directory Key (DIR)
3 Dialpad/Dedicated Function Keys	8 One Touch Keys	13 Message Key (MSG)
4 Microphone	9 Hookswitch	14 MIC Key
5 Volume Control	10 Built-in Headset Jack	

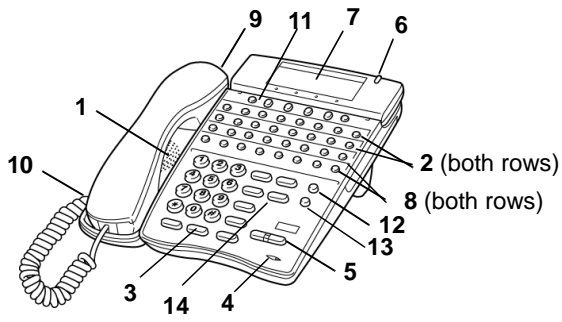

32-Button Display  
with 16 DSS/BLF  
One Touch Keys

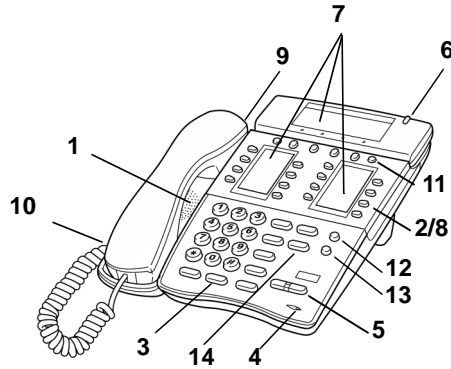

16-Button Multiline  
Liquid Display

1	Speaker	6	Large LED	11	Softkeys
2	Line Keys/Feature Access Keys	7	Alphanumeric Display	12	Directory Key (DIR)
3	Dialpad/ Dedicated Function Keys	8	One Touch Keys	13	Message Key (MSG)
4	Microphone	9	Hookswitch	14	MIC Key
5	Volume Control	10	Built-in Headset Jack		

## **GENERAL INFORMATION**

The following should be considered when reviewing this User Guide:

- All operational instructions assume Prime Line Pickup is assigned to intercom dial tone, Ringing Line Preference is assigned to all telephones, a Line and Second Incoming Extension key has been assigned to all multiline telephones and only a single tenant has been assigned in the system.
- All access codes listed are standard; some may vary based on system assignment.
- Access to many features is based on system assignments. Not all features may be available from your telephone.
- Telephones equipped with displays will provide useful call processing information such as digits dialed, recall indications, feature confirmation, etc.

## LED INDICATIONS

Function	Lamp Status
<b>CO LINE KEYS:</b> Incoming Call Held Call - Your Telephone Held Call - Other Telephone Call in Progress Your Telephone Other Telephone Hold Recall	Rapid Flashing Red Slow Flashing Green Slow Flashing Red  Steady Green Steady Red Intermittent Flashing Green
<b>LARGE LED:</b> Incoming CO/PBX, CIT, or ANA Call Incoming Intercom, TIE Line, or DID Call Message from Attendant Voice Mail Message	Rapid Flashing Green  Rapid Flashing Red  Slow Flashing Green Slow Flashing Red
<b>FEATURE KEY:</b> DND Set Call Forward Set Callback Request	Intermittent Flashing Red Intermittent Flashing Red Slow Flashing Red
<b>ICM LED:</b> Incoming Call Call in Progress Held Call	Flashing Red Steady Red Flashing Red Conf LED

# ANSWERING CALLS

## Ringling Calls

1. Lift the handset.
2. Converse.

**Note:** When assigned the Delayed Ringing feature, incoming calls will first ring at a primary station. If the call is unanswered after a preprogrammed time interval, calls will also ring at the assigned secondary station.

## Ringling Calls To A Second Incoming Extension Key

1. Lift the handset.
2. Converse.

**Note 1:** A **Second Incoming Extension** key must be assigned to appear and ring.

**Note 2:** A **Line** key must be available to answer an incoming outside call.

## Voice Announce Calls

1. Ensure the **MIC** LED is lit.
2. Adjust the **Speaker volume** (▼ or ▲) as needed.
3. Respond handsfree.

**Note:** The handset may be used at any time during the conversation.

## Camp-on (Call Waiting)

Receive camp-on tone while on another call:

1. Replace the handset to disconnect present call.

**OR**

Press **Hold** and press the **Hookswitch** to converse with the second party.

## Call Alert Notification

With a call in progress:

1. Receive a Call Alert Notification.
2. Press the **Hold** key, then converse with the second party.

**Note 1:** The second call may be placed on **Hold** if a Line appearance is assigned.

**Note 2:** Press the flashing **Line** key or **Conf** key to return to the first call.

## PLACING CALLS

### Internal Calls

1. Lift the handset.
2. Dial a station number or **0** for the attendant.

**OR**

Press the **Feature Access** key or **One Touch** key programmed for Direct Station Select.

3. Voice announce after the tone burst or wait for the ringing call to be answered.

**Note 1:** When calling a multiline telephone, dialing **1** after the station number will change ringing to voice or voice to ringing.

**Note 2:** To directly access a personal voice mailbox, dial **7** after dialing the station number.

## Outside Calls

1. Lift the handset.
2. Dial the **trunk access code**, i.e. **9**.

**OR**

Press an idle **Outside Line** key.

3. Dial the telephone number.
4. Converse.

## Trunk Queuing

After dialing the trunk access code or pressing a busy Line key and receiving the trunk busy indication:

1. Dial the Trunk Queue set code **78**.
2. Replace the handset.

**Note:** When a line is available, your telephone will ring; lift the handset and place the call.

## Last CO/PBX Number Redial

1. Lift the handset.
2. Press the **Redial** key.
3. Dial the Last Number Redial code **\***.
4. Converse.

## Station/System Speed Dial

1. Lift the handset.
2. Press the **Redial** key and dial the **Speed Dial Memory** location:
  - Station Speed Dial **80~99**.
  - System Speed Dial **00~79**.

**OR**

Press the **Feature Access** key or **One Touch** key programmed for the Station Speed Dial.

3. Converse.

## Scrolling Speed Dial Directories

1. Press the **Speed Dial** Softkey.
  - SYS System Speed Dial
  - STA Station Speed Dial
2. Press the **UP/DOWN** Softkeys to scroll through all the entries.

**OR**

Use the dial pad to enter the first letter of the desired entry then dial **\***.

Press the **UP/DOWN** Softkeys to scroll.

Lift the handset or press the **Speaker** key or press an idle **Outside Line** key to place a call to the displayed entry.

**OR**

Press **Feature** or **Exit** or wait 10 seconds to cancel.

**Note:** For example, when using the dial pad to search the directory for the name "Ann", dial the number **2** on the dial pad followed by **\***. To search for "Bob", dial the number **2** twice and then **\***. To search for "Carol", dial the number **2** three times and then **\***. To search for "Dan", dial the number **3** followed by **\***.

## MICROPHONE CONTROL

1. Press the **MIC** key.
2. A lit **MIC** LED indicates that the **MIC** is on.

## SPEAKERPHONE CALLS

1. Press the **Speaker** key and the LED lights.
2. Ensure that the **MIC** LED is lit.
3. Place internal or outside call.
4. Converse.
5. Press the **Speaker** key to disconnect call.

**Note:** The handset may be used at any time during the conversation. To resume handsfree operation or to monitor a call, press the **Speaker** key (the LED lights) and replace the handset.

## GROUP LISTENING

With a call in progress via the handset/headset:

1. Press the **Speaker** key, then the LED lights.
2. Converse. Conversation is heard over the speaker and the handset/headset. Only the handset/headset may be used to respond.
3. Press **Speaker** to cancel the Group Listening mode.

**Note:** When switching from Group Listening mode to the Speakerphone mode, it is recommended that the Microphone be turned off.

## HOLDING CALLS

### **Non-Exclusive Hold**

With a call in progress:

1. Press **Hold**.

### **Exclusive Hold**

With a call in progress:

1. Press **Feature**.
2. Press **Hold**.

**Note 1:** To retrieve a held call, press the flashing Line key or Conf key (internal calls).

**Note 2:** Calls on Non-Exclusive Hold can be retrieved from any multiline telephone with the held line appearance.

**Note 3:** After a preprogrammed time, the held call will recall to the originating station. Once in a recall condition, Exclusively Held calls can be retrieved from any station with the held line appearance.

## TRANSFERRING CALLS

### **Using Manual Dial**

With a call in progress:

1. Press the **Transfer** key.
2. Dial the station number.
3. Announce the call (optional).
4. Replace the handset.

### **Using Direct Station Selection (DSS)**

With a call in progress:

1. Press the **Transfer** key.
2. Press the programmed **DSS**.
3. Announce the call (optional).
4. Replace the handset.

**Note 1:** If the called station is busy, replace the handset to initiate a camp-on. Unanswered camp-ons and unscreened transfers will recall to the attendant telephone. After answering the recall, pressing the **Feature** key and then **86** will transfer the call to the personal voice mailbox of the station number dialed.

**Note 2:** To return to the original party, press the flashing **Line** key or **Conf** key.

**Note 3:** A **Feature Access** key or **One Touch** key may be assigned for DSS.

**Note 4:** To transfer a call directly to a personal voice mailbox, dial 7 after dialing the station number.

## CONFERENCE

With a call in progress:

1. Press the **Conf** key.
2. Place the second call (internal or external).
3. Announce the conference.
4. Press the **Conf** key to establish the conference.

**Note 1:** Repeat the above procedure to add an additional party (maximum of 2 for outside calls or 3 inside calls).

**Note 2:** An unsupervised conference may be established by pressing the **Conf** key again, after the conference has been established. The parties may continue to converse in private. Press the flashing **Conf** key to return to the conversation. This feature is available if programmed in your system by your system administrator.

## CONFERENCE BRIDGE

To make a call using a Conference Bridge:

1. Call a Conference Bridge extension.
2. When the voice prompt is heard, enter the password and press **#**.
3. Start the conference call.

Start a conference call from an incoming CO call using an Automated Attendant:

1. Call an outside line that is answered by an Automated Attendant.
2. Dial the extension of the Conference Bridge.
3. When the voice prompt is heard, enter the password and press #.
4. Start the conference call.

Start a conference call from an off premise location:

1. Call a line that is directed to the Conference Bridge.
2. When the voice prompt is heard, enter the password and press #.
3. Start the conference call.

Start a conference call from an incoming CO call using an Attendant:

1. Call the Attendant and ask to be transferred to a Conference Bridge extension.
2. Wait until the transfer is complete.
3. When the voice prompt is heard, enter the password and press #.
4. Start the conference call.

**Note:** Default passwords: Conference #1 = **0001**  
Conference #2 = **0002**

## CALL PARK - SYSTEM

### **Set**

With a call in progress:

1. Press the Transfer key.
2. Dial Call Park Set code **4 \***.
3. Dial Call Park location **0~9**.
4. Replace the handset.

### **Retrieve**

From any station:

1. Lift the handset.
2. Dial Call Park Retrieval code **4 #**.
3. Dial Call Park location **0~9**.
4. Converse.

**Note:** If the dialed Call Park location is busy, dial another Call Park location **0~9**.

## STATION BUSY/NO ANSWER OPTIONS

### **Automatic Callback**

#### **Set**

When calling a busy multiline telephone:

1. Dial the Automatic Callback code **0**.
2. Replace the handset.

#### **Answer**

When both telephones are idle originating telephone rings:

1. Lift the handset.
2. Call is placed automatically.

## Callback Request

### Set

When calling a busy or unanswered multiline telephone:

1. Dial the Callback Request code #.
2. Replace the handset.

### Answer

Receive a display and/or **Feature** LED message indication:

1. Lift the handset.
2. Dial #: the requested originator is automatically called.

**Note:** Callback messages are automatically canceled once the origination station is called.

## Tone Override

### Set

When calling a busy multiline telephone:

1. Dial the Tone Override code \* to send the tone.
2. Wait for a signaled party to answer.

### Answer

When a call is in progress:

1. Receive a tone override signal.\*
2. Press the **Hold** key.
3. Converse with the second party.

\* If handsfree, a visual indication only ( \* ) will be provided on the telephone display.

**Note:** An Override Tone will be sent each \* is pressed.

## Step Call

When calling a busy telephone:

1. Dial **2** to advance to the next station number in that 10's group.

## Voice Over

### Originate

When calling a busy telephone:

1. Dial the Voice Over code **6**.
2. Announce the message.

### Answer

With a call in progress:

1. Receive the Voice Over announcement.
2. Press the **Hold** key.
3. Converse with the Voice Over originator.
4. Press the **Answer** key to alternate between parties.

### Whisper Page

With a call in progress:

1. Receive the Voice Over announcement.
2. Press the **Feature** key.
3. Dial **65**.
4. Converse with the Voice Over originator while monitoring the first call.
5. Press the **Feature** key again.
6. Dial **65** again.
7. Converse with the first caller while monitoring the Voice Over originator.

**Note:** The Whisper Page Access Code may be assigned to a **Feature Access** key or a **One Touch** key.

## CO/PBX DIALING OPTIONS

### Save & Repeat

#### Save

With an originating outside call in progress:

1. Press the **Feature** key.
2. Dial **9** and the called number is stored.
3. Replace the handset.

#### Repeat

1. Lift the handset.
2. Press the **Redial** key.
3. Dial **#** and the call is placed.

## Store & Repeat

### Store

With an outside call in progress:

1. Press the **Feature** key.
2. Dial **7**
3. Dial the number to be stored.
4. Press the **Feature** key.
5. Complete the conversation and replace the handset.

### Repeat

1. Lift the handset.
2. Press the **Redial** key.
3. Dial **#** and the call is placed.

**Note:** Store & Repeat and Save & Repeat features cannot be used simultaneously.

## Automatic Redial

After originating a busy or unanswered outside call:

1. Press the **Speaker** key or replace the handset.
2. Press the **Feature** key.
3. Press the **Redial** key.
4. The call is repeatedly dialed until answered, canceled, or the maximum number of redial attempts is reached.
5. Lift the handset when the called party answers.

**Note 1:** Press the **Speaker** key to cancel the Automatic Redial.

**Note 2:** System programming determines the waiting time and the number of redial attempts.

## Caller ID

### Answer

Receive incoming ringing or transferred outside call:

1. Review the telephone display for the calling party's name or number.
2. Answer the call accordingly.

### Place Call ID Calls

1. Press the Directory key repeatedly until the desired number is displayed.
2. Lift the handset to automatically dial the displayed number.
3. Converse.

**Note 1:** Caller ID will be displayed even when the station is busy or in DND mode, allowing the user to identify the incoming call.

**Note 2:** On a per station basis, the last 50 calls answered with Caller ID information are stored and are accessible with the Directory key.

**Note 3:** Press the lit Line key to review the calling party's name or number while the call is in progress.

## CALL PICKUP

### Call Pickup System

Upon hearing ringing at another telephone:

1. Lift the handset.
2. Dial the Call Pickup code:
  - All Calls **68**
  - CO/PBX Line **6 \***
  - Night Call Pickup **6**
3. Converse.

### Call Pickup Direct

Upon hearing ringing or voice announcement at another telephone:

1. Lift the handset.
2. Dial the Call Pickup Direct code **67**.
3. Dial the station number of the telephone to be answered.
4. Converse.

## PAGING

1. Lift the handset.
2. Dial the Paging code:

	<b>Internal</b>		<b>External</b>	
	All Zones	<b>51</b>	All int. & ext.	<b>59</b>
	Zone A	<b>52</b>	All Zones	<b>55</b>
	Zone B	<b>53</b>	Zone A	<b>56</b>
	Zone C	<b>54</b>	Zone B	<b>57</b>
			Zone C	<b>58</b>
3. Page.
4. Wait for the Meet-Me Answer or replace the handset.

## **Meet-Me Answer**

1. Lift the handset.
2. Dial the Meet-Me Answer code:

Internal Page	<b>5 *</b>
External page	<b>5 #</b>
3. Converse.

## BACKGROUND MUSIC

### **Set/Cancel**

1. Press the **Feature** key.
2. Dial BGM On/Off code **26**.

**Note:** A BGM key may be assigned in system programming to set/cancel the Background Music feature.

## CALL FORWARDING

### All Calls (CF/A)/Do Not Disturb (DND)

#### Set

1. Press the **Feature** key.
2. Dial Call Forward All/DND set code **60**.
3. Select operation:
  - DND: Press the **Feature** key.
  - Call Forward All: dial the destination station number or voice mail or trunk access code and outside number and press the **Feature** key.

#### Cancel

1. Press the **Feature** key.
2. Dial Call Forward All/DND set code **69**.
3. Press the **Feature** key again.

**Note 1:** The Feature LED will flash intermittently when your telephone is in Call Forward/DND.

**Note 2:** While set, Call Forward All will override Call Forward Busy/No Answer setting.

**Note 3:** If Call Forward All and Do Not Disturb are both set, the feature set last is activated.

**Note 4:** A CFA/DND key may be assigned in system programming to set/cancel this feature. When setting Call Forward All, a destination station must be entered. A lit LED indicates that Call Forward All/Do Not Disturb is set.

## Call Forward Busy/No Answer (B/NA)

### Set

1. Press the **Speaker** key.
2. Dial Call Forward B/NA set code **43**.
3. Dial the destination station number or voice mail or trunk access code and the outside number.
4. Press the **Speaker** key again.

### Cancel

1. Press the **Speaker** key.
2. Dial Call Forward cancel code **44**.
3. Press the **Speaker** key again.

**Note 1:** While set, Call Forward All will override Call Forward Busy/No Answer setting.

**Note 2:** A CF B/NA key may be assigned in system programming to set/cancel this feature. When setting Call Forward Busy/No Answer, a destination station must be entered. A lit LED indicates that CF B/NA is set.

## CUSTOMIZED MESSAGE

From a display telephone:

1. Press the **Feature** key.
2. Dial the Customized Message code **70**.
3. Dial **\*** to scroll through messages.
4. Dial **#** to select a message.
5. Dial the return date and time if required (Month/day, Hour/Minute, using the 4-digit 24-hour clock).
6. Press the **Feature** key again.

**Note:** You must place your telephone in **Do Not Disturb**; other display telephones will then receive your message upon calling your station.

## SET RELOCATION

1. Ask the Attendant to turn on Set Relocation Mode.
2. From the new location, press the **Speaker** key, the LED then lights.
3. Dial Set Relocation code \_\_\_\_\_.
4. Dial **your** station number.
5. Dial the Station Password [same as the Station Lockout (Password) code].
6. Hear the confirmation tone and then press the **Speaker** key.
7. Inform the Attendant that your relocation is complete and request that the Attendant turn **Set Relocation Mode** off.

## STATION OUTGOING LOCKOUT

### Changing Lockout (Password) Code

1. Press the **Speaker** key.
2. Dial the Lockout (Password) Change access code \_\_\_\_\_.
3. Dial the current Lockout (Password) code.
4. Dial the new Lockout (Password) code.
5. Press the **Speaker** key again.

**Note 1:** By default, the Lockout (Password) code is set at **0000000000** (10 zeros).

**Note 2:** When the Lockout (Password) code is set for the first time, the station is automatically restricted.

**Note 3:** Lockout (Password) code may be a maximum of 10 digits. If the new Lockout (Password) code is less than 10 digits, press the Speaker key to enter.

**Note 4:** When set, the Station Outgoing Lockout restricts all outgoing calls.

## Set/Cancel Station Outgoing Lockout

1. Press the **Speaker** key.
2. Dial the Station Lockout.
  - Set code \_\_\_\_\_
  - Cancel code \_\_\_\_\_
3. Dial the Lockout (Password) code.
4. Press the **Speaker** key again.

## ACCOUNT CODE ENTRY

With an outside call in progress:

1. Press the **Feature** key.
2. Dial **66**.
3. Dial Account Code (16 digits maximum).
4. Press the **Feature** key.

With an outside call on hold:

1. Dial the Account Code Entry Code \_\_\_\_\_.
2. Dial Account Code (16 digits maximum).
3. Retrieve the held call.

**Note 1:** The outside party will not hear the digits being dialed.

**Note 2:** The Account Code Entry Code may be assigned to a **Feature Access** key or **One Touch** key.

## AUTHORIZATION CODE FORCED/VERIFIED

To place an outside call:

1. Lift the handset.
2. Dial the Forced Account access code \_\_\_\_.
3. Dial the Forced Account Code \_\_\_\_ (up to 13 digits).
4. Dial the trunk access code, i.e. **9** and the outside number.

**Note:** When calling from a station that is assigned the Account Code Forced/Verified feature, outgoing calls will only be processed after the dialed Account Code is verified.

## DISA PASSWORD

### Setting Your DISA Password

1. Lift the handset.
2. Dial the DISA Password set access code \_\_\_\_.
3. Dial your DISA ID code \_\_\_\_.
4. Dial your current DISA password [same as the Station Lockout (Password) code].
5. Dial your new DISA password.
6. Replace the handset.

**Note 1:** The password may be a maximum of 10 digits. If the new password is less than 10-digits, replace the handset to enter.

**Note 2:** It is recommended that your DISA password be 10 digits and be changed frequently to prevent unauthorized use.

## ACD/UCD

### Log On

1. Press the **Speaker** key.
2. Dial the access code \_\_\_\_.
3. Dial **1**.
4. Press the **Speaker** key again.

### Log Off

1. Press the **Speaker** key.
2. Dial the access code \_\_\_\_.
3. Dial **2**.
4. Press the **Speaker** key again.

**Note 1:** A LOG key may be assigned in system programming to Log On/Off from the ACD/UCD group. A lit LED may indicate that the station is logged on.

**Note 2:** With the Elite ACD Plus, these procedures are done using the softkey functions. Refer to your Elite ACD Plus User Guide for more details.

## Break Mode

### Set

1. Press the **Speaker** key.
2. Dial **40**.
3. Press the **Speaker** key again.

### Cancel

1. Press the **Speaker** key.
2. Dial **42**.
3. Press the **Speaker** key again.

**Note 1:** Break Mode is only available while an agent is logged on.

**Note 2:** A Break key may be assigned in system programming to set/cancel Break Mode. A lit LED indicates that the station is in Break Mode.

## Answering a Call Using a Headset

1. Press the **Headset** key to answer.
2. Converse.
3. Press the **Headset** key to hang up.

## VOLUME CONTROL

### Off-Hook Ringing Volume

#### Off-Hook Ringing volume

1. Lift the handset.
2. Dial **60**.
3. Dial Off-Hook Ringing Volume code **1**.
4. Press ▼ or ▲ to set level.
5. Replace the handset.

#### Ringling volume

1. Press the Speaker key.
2. Dial **60**.
3. Dial Ringing Volume code **1**.
4. Press ▼ or ▲ to set level.
5. Press the Speaker key again.

**Note 1:** Press ▼ or ▲ during audible telephone activity to adjust the handset or speaker volume.

**Note 2:** When the telephone is idle, ▼ or ▲ is used to adjust the display contrast.

## PROGRAMMING

### Resetting Feature LED

1. Press the **Feature** key.
2. Dial **99**.
3. Press **Feature** key again.

**Note:** Resetting the Feature LED will cancel Call Forward All Calls, Do Not Disturb, and Callback Request settings.

## Station Speed Dial — Dial Access

1. Press the **Feature** key.
2. Press the **Redial** key.
3. Dial the Speed Dial Memory location **80~99**.
4. Dial the trunk access code, i.e. **9** (if necessary).
5. Dial the telephone number to be stored (24 digits maximum).
6. Press the **Hold** key (if entering a name) and dial the name of the party (13 letters maximum).
7. Press the **Feature** key again

**Note 1:** Press the **Redial** key to insert a pause or Recall to store a hookflash.

**Note 2:** Use the dial pad on the telephone when entering the name of the party.

## Feature Access Keys

### Station Speed Dial (Outside Numbers)

1. Press the **Feature** key.
2. Press the **Redial** key.
3. Press the **Feature Access** key to be programmed.
4. Dial **0**.
5. Dial the trunk access code, i.e. **9** (if necessary).
6. Dial the telephone number to be stored (16 digits maximum).
7. Press the **Feature** key again.

### DSS/BLF (Stations) and Feature Access

1. Press the **Feature** key.
2. Press the **Redial** key.
3. Press the **Feature Access** key to be programmed.
4. Dial **1** and the station number to be stored.

#### OR

Dial the feature access code to be stored as indicated in the **Quick Entry Guide**.

5. Press the **Feature** key again.

**Note 1:** Press the **Redial** key to insert a pause or **Recall** to store a hookflash.

**Note 2:** The Busy Lamp Field status indication will be provided on the keys programmed for DSS.

## One Touch Keys

### Station Speed Dial (Outside Numbers)

1. Press the **Feature** key.
2. Press the **Redial** key.
3. Press the **One Touch** key to be programmed.
4. Dial **0**.
5. Dial the trunk access code, i.e. **9** (if necessary).
6. Dial the telephone number to be stored (16 digits maximum).
7. Press the **Feature** key again.

### DSS/BLF (Stations) and Feature Access

1. Press the **Feature** key.
2. Press the **Redial** key.
3. Press the **One Touch** key to be programmed.
4. Dial **1** and the station number to be stored.

#### OR

Dial the feature access code to be stored as indicated in the **Quick Entry Guide**.

5. Press the **Feature** key again.

**Note 1:** Press the **Redial** key to insert a pause or **Recall** to store a hookflash.

**Note 2:** The Busy Lamp Field status indication will be provided on the keys programmed for DSS.

## QUICK ENTRY GUIDE

For programming Feature Access keys and One Touch keys.

<b>Feature</b>	<b>Press</b>
Microphone On/Off	# ➤ 1 ➤ <b>Feature</b> or <b>MIC</b>
Call Forward All – Set	# ➤ 60 ➤ Dial Destination ➤ <b>Answer</b> ➤ <b>Feature</b> ➤ <b>Feature</b>
Do Not Disturb – Set	# ➤ 60 ➤ <b>Answer</b> ➤ <b>Feature</b> ➤ <b>Feature</b>
Call Forward All/DND – Cancel	# ➤ 60 ➤ Dial Destination ➤ <b>Answer</b> ➤ <b>Feature</b> ➤ <b>Feature</b>
Save & Repeat – Set	# ➤ 9 ➤ <b>Feature</b>
Store & Repeat – Set	# ➤ 7 ➤ <b>Feature</b>
Whisper Page	# ➤ 65 ➤ <b>Feature</b>
Quick Transfer to Voice Mail	# ➤ 86 ➤ <b>Feature</b>
Background Music	# ➤ 26 ➤ <b>Feature</b>
Voice Over Originate	# ➤ <b>Answer</b> ➤ <b>Feature</b> ➤ 6 ➤ <b>Feature</b>
Call Forward Busy/No Answer – Set	1 ➤ 43 ➤ Dial Destination ➤ <b>Answer</b> ➤ <b>Speaker</b> ➤ <b>Feature</b>
Internal Paging All Zone	1 ➤ 51 ➤ <b>Feature</b>
Internal Paging Meet-Me	1 ➤ 5 * ➤ <b>Feature</b>
External Paging All Zone	1 ➤ 55 ➤ <b>Feature</b>
External Paging Meet-Me	1 ➤ 5 # ➤ <b>Feature</b>
Call Pickup All Calls	1 ➤ 68 ➤ <b>Feature</b>
Call Pickup Direct	1 ➤ 67 ➤ <b>Feature</b>

**Note 1:** When pressed, the **Answer** key will not appear in the display. This is normal operation.

**Note 2:** Other features may be programmed in addition to those listed above. Refer to the EliteMail User Guide for features related to Voice Mail.

## Character Entry

To add a name to each speed dial entry, use the Character Entry Code table OR press the dial pad number corresponding to the alpha character desired (six characters maximum).

- i.e. 2 = A, B, D, a, b, c, or 2  
3 = D, E, F, d, e, f, or 3  
4 = G, H, I, g, h, i, or 4

For the name Bob press: **2-2-6-6-6-2-2**

## Character Entry Codes

Character	Code	Character	Code	Character	Code
Blank	032	6	054	L	076
!	033	7	055	M	077
	034	8	056	N	078
#	035	9	057	O	079
\$	036	:	058	P	080
%	037	;	059	Q	081
&	038	<	060	R	082
'	039	=	061	S	083
(	040	>	062	T	084
)	041	?	063	U	085
*	042	@	064	V	086
+	043	A	065	W	087
,	044	B	066	X	088
-	045	C	067	Y	089
-	046	D	068	Z	090

Character	Code	Character	Code	Character	Code
/	047	E	069	[	091
0	048	F	070	¥	092
1	049	G	071	]	093
2	050	H	072	^	094
3	051	I	073	_	095
4	052	J	074	\	096
5	054	K	075	a	097
b	098	l	108	v	118
c	099	m	109	w	119
d	100	n	110	x	120
e	101	o	111	y	121
f	102	p	112	z	122
g	103	q	113	{	123
h	104	r	114		124
i	105	s	115	}	125
j	106	t	116	→	126
k	107	u	117		127

# Speed Dial Name Input

Characters must be entered using the dial pad instead of the Character Entry Codes.

Press	1	2	3	4	5	6	7	8	9	0	*	#
1 <sup>st</sup>	1	A	D	G	J	M	P	T	W	0	*	Set
2 <sup>nd</sup>	@	B	E	H	K	N	Q	U	X	!	+	Space
3 <sup>rd</sup>	[	C	F	I	L	O	R	V	Y	“	,	To Set
4 <sup>th</sup>	¥	a	d	g	j	m	S	t	z	#	-	
5 <sup>th</sup>	]	b	e	h	k	n	p	u	w	\$	.	
6 <sup>th</sup>	^	c	f	i	l	o	q	v	x	%	/	
7 <sup>th</sup>	_	2	3	4	5	6	r	8	y	&	:	
8 <sup>th</sup>	'	To A	To D	To G	To J	To M	s	To T	z	'	;	
9 <sup>th</sup>	{						7		9	(	<	
10 <sup>th</sup>							To P		To W	)	=	
11 <sup>th</sup>	}									To 0	>	
12 <sup>th</sup>	➤										?	
13 <sup>th</sup>	➤										To *	
14 <sup>th</sup>	To 1											
Conf	Clear and 1 Character Back From The Cursor											

## QUICK REFERENCE GUIDE

<b>Outside Calling</b>	
Outside Call	Dial <b>9</b> ➤ Dial Telephone Number
Last CO/PBX Number Redial	Redial ➤ Dial *
Speed Dial	Redial ➤ Dial <b>00~99</b>
Save/Store & Repeat — Access	Redial ➤ Dial #
Trunk Queue	Receive Trunk Busy Indication ➤ Dial <b>78</b>
Automatic Redial	Receive Busy ➤ <b>Speaker</b> ➤ Replace Handset ➤ <b>Feature</b> ➤ <b>Redial</b>
<b>Internal Calling</b>	
Station Call	Dial Station Number or <b>DSS</b> key
Automatic Callback	Reach Busy Station > Dial #
Callback Request	Reach Busy No Answer Station ➤ Dial #
Tone Override	Reach Busy Station ➤ Dial *
Voice Over Originate	Reach Busy Station ➤ Dial <b>6</b>
Quick Transfer to Voice Mail	Dial Station Number ➤ Dial <b>7</b>
<b>With A Call in Progress</b>	
Hold	<b>Hold</b>
Exclusive Hold	<b>Feature</b> ➤ <b>Hold</b>
Transfer	<b>Transfer</b> ➤ Dial Station Number
Quick Transfer to Voice Mail	<b>Transfer</b> ➤ Dial Station Number ➤ Dial <b>7</b>

<b>With A Call in Progress (continued)</b>	
Conference	<b>Conf</b> ➤ Place 2nd Call ➤ <b>Conf</b>
Call Park System	SET: <b>Transfer</b> ➤ Dial 4 * ➤ Dial 0~9
	RETRIEVE: Dial 4 # ➤ Dial 0~9
Save & Repeat — Save	<b>Feature</b> ➤ Dial 9
Store & Repeat — Store	<b>Feature</b> ➤ Dial 7 ➤ Dial Number to Store ➤ <b>Feature</b>
Whisper Page	Receive Voice Over ➤ <b>Feature</b> ➤ Dial 65
<b>From the Intercom</b>	
Internal Paging	Dial 51~54 ➤ <b>Page</b>
External Paging	Dial 55~59 ➤ <b>Page</b>
Call Pickup All Calls	Dial 68
Call Pickup Direct	Dial 67 ➤ Dial Station Number
<b>From An Idle Telephone</b>	
Microphone Control	<b>Feature</b> ➤ Dial 1 or <b>MIC</b>
Call Forward All/DND	SET: <b>Feature</b> ➤ Dial 60 ➤ Dial Destination (CF/A only) <b>Feature</b>
	CANCEL: <b>Feature</b> ➤ Dial 69 ➤ <b>Feature</b>
Call Forward Busy/No Answer	SET: <b>Speaker</b> ➤ Dial 43 ➤ Dial Destination ➤ <b>Speaker</b>
	CANCEL: <b>Speaker</b> ➤ Dial 44 ➤ <b>Speaker</b>
FNC LED Reset	<b>Feature</b> ➤ Dial 99 ➤ <b>Feature</b>

© 2003 NEC America, Inc.

The material contained herein is subject to change without prior notice at the sole discretion of NEC America, Inc.

Electra Elite is a registered trademark of NEC Corporation.

Document Revision 2

For more information contact:

NEC America, Inc.  
6555 N State Highway 161  
Irving, TX 75039-2402

**[www.cng.nec.com](http://www.cng.nec.com)**

**780315**

**NEC**